

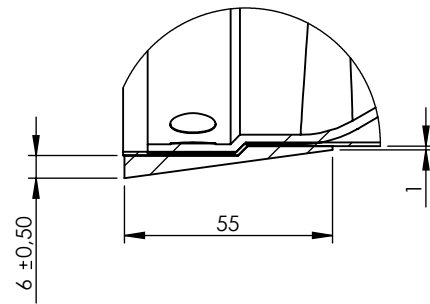

Rev	Note	CreatedBy	Appr.By	Appr.Date
A	Initial release	FG	AE	2019-12-03

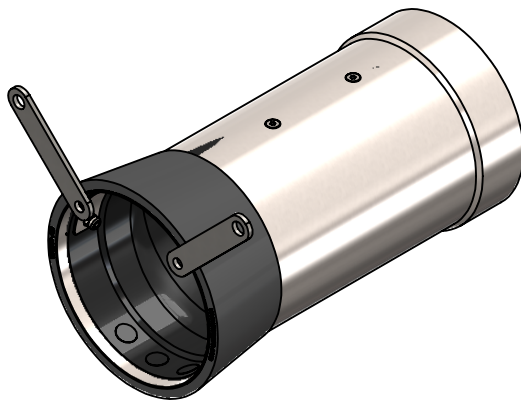
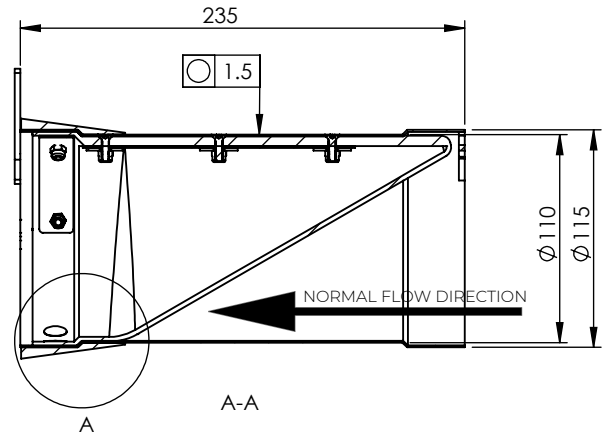
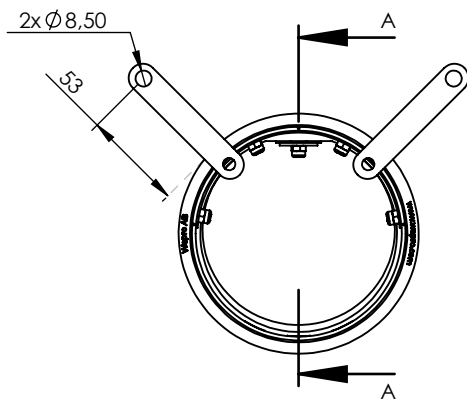

DETAIL A  
SCALE 1 : 2

© 2018 Wapro AB. This document is subject to copyrights owned by Wapro AB. Any amendments, republication, retransmission, and/or reproduction of all or any part of the document is expressly prohibited, unless the copyright owner of the material has expressly granted its prior written consent. All other rights are reserved.

Designed By FG	Approved By AE	Created Date 2019-12-03	Units [mm]	General Tolerance ISO 13920A	Scale 1:4	
Material EN 1.4404			Project			Comments
Weight [kg] 1,01		Box Volume [m³] 0,003	Description WaStop DN125			
 <a href="http://www.wapro.com">www.wapro.com</a>			Article Number WS116-S	Drawing Number ws116-s-en	Rev A	Sheet 1 (1)